

NC2030



A high performance, low power, image rejecting DC transceiver for either 20 or 30m

Dan Tayloe, N7VE; Trevor Jacobs, K6ESE

Front View – 20m Prototype

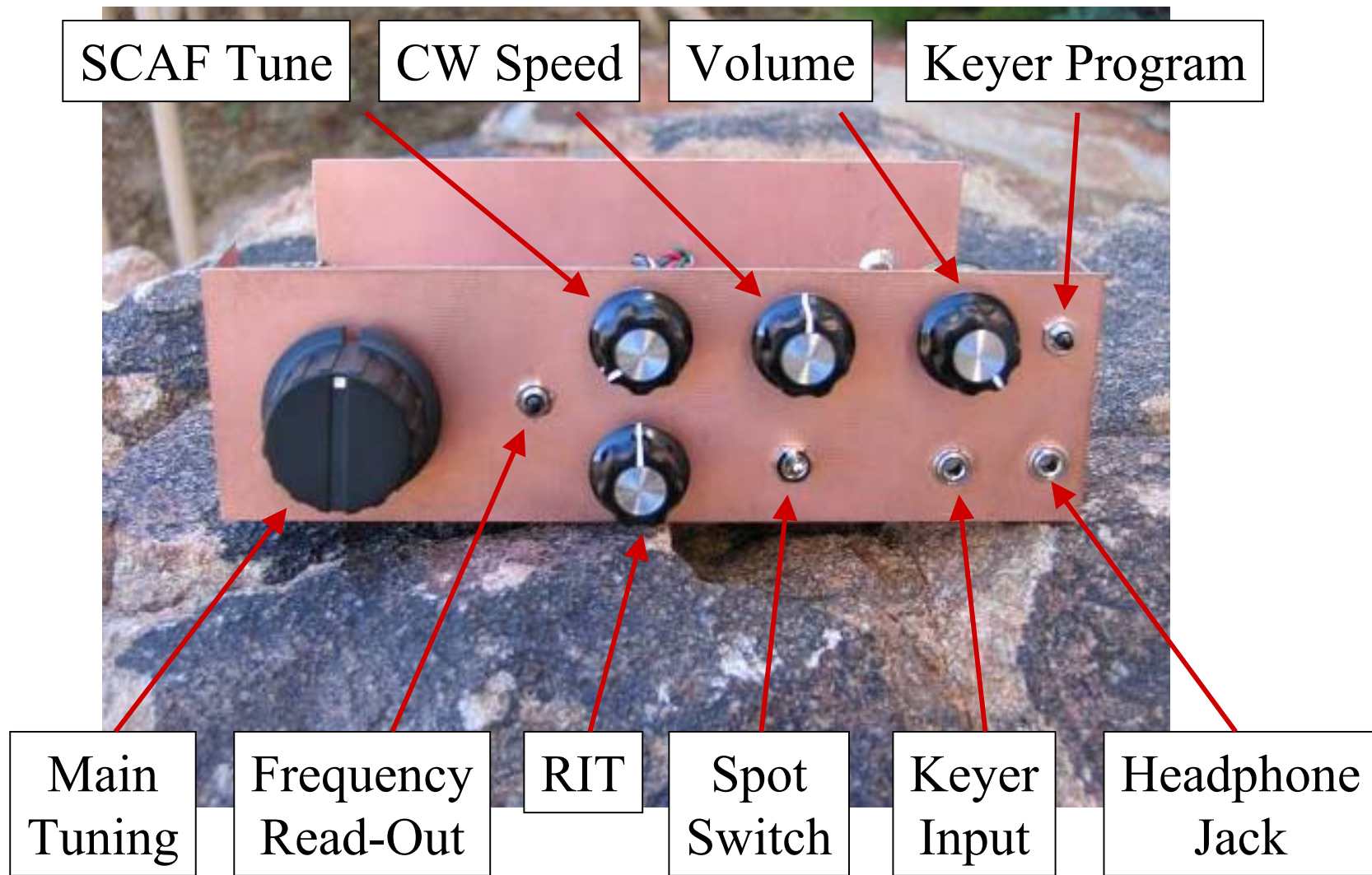

Back View

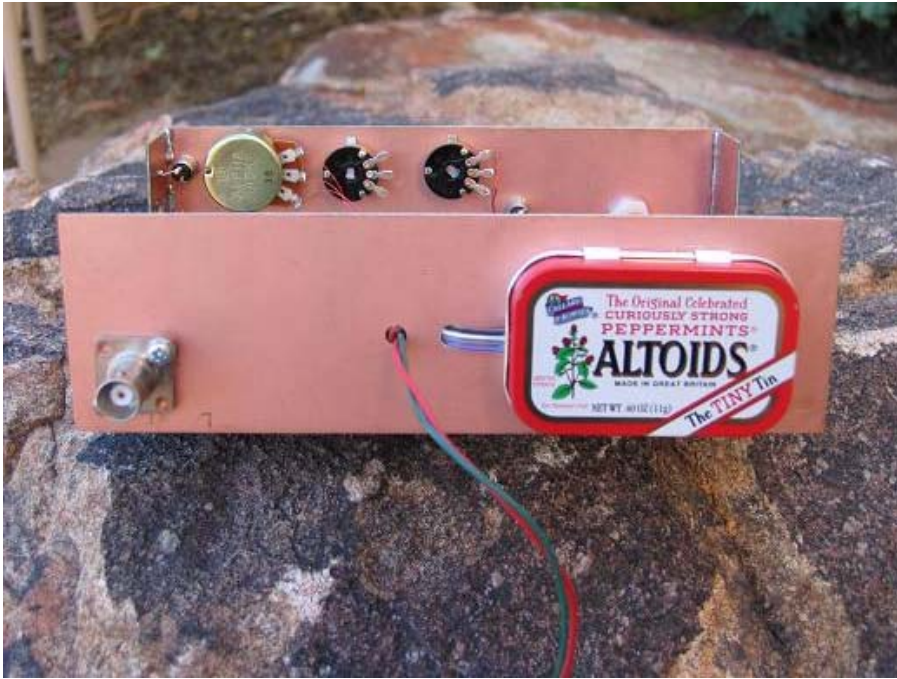

Under-the-hood view of the receiver switching power supply.

7v to 15v in, 3v and 5v out



Prototype NC2030 board – K6ESE

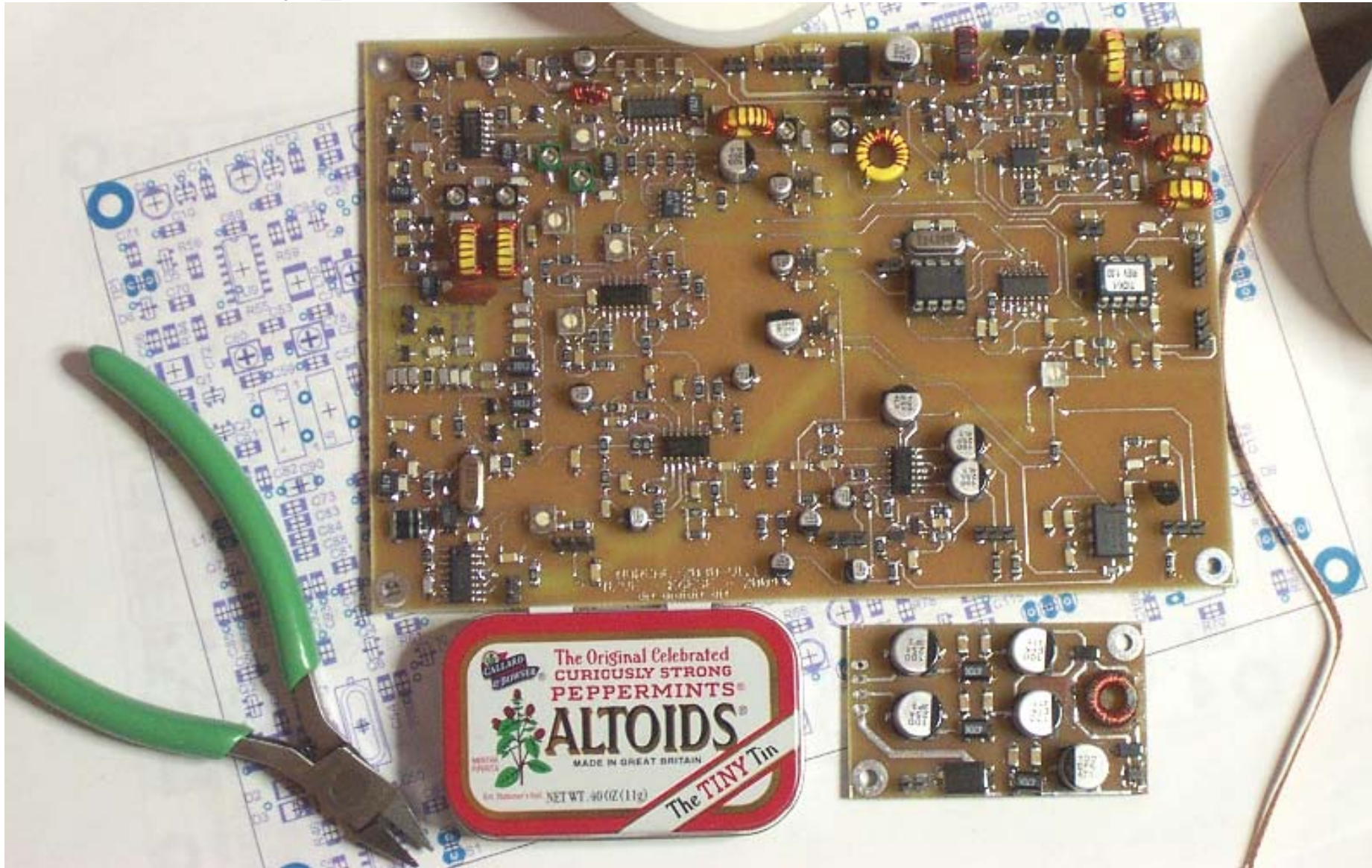

10/16/04

NC2030 Presentation. Copyright 10/04, N7VE All rights reserved

NC2030 Novel Features

- High performance quadrature detector with outstanding IP3 and blocking performance
- Low current drain 3v receiver
- *5w, high efficiency, SWR protected, no tune class E PA*
- No-ring 500 Hz BW audio filtering with sharp audio roll off.
- Auxiliary variable tune SCAF audio LPF.
- *Switching supply* used to efficiently convert 7v to 14v input to *3v* and *5v* outputs.

A few specifications....

As measured from 20m/30m prototypes

- Receiver current drain
 - **13.8v: 9.5 ma (30m), 11 ma (20m)**
 - 7.3v: 17.2 ma (30m), 18.7 ma (20m)
- Transmitter
 - Fixed power Class E output
 - SWR protected PA
 - **5w at 13.8v, 550 ma**
 - 4w at 12v, 500 ma
 - **1.2w at 6.5v, 300 ma**

Norcal 2030 Rx Specification

- Receiver Type: Direct Conversion with Phasing
- > 45 db opposite sideband suppression
- Tuning range:
 - 14.000 – 14.070 MHz *or* 10.100 – 10.150 MHz
- Receiver sensitivity: -135 dbm, 3 db S+N/N
- Blocking:
 - *+6 dbm @ 10 KHz (141 db BDR)*
 - -4 dbm @ 5 KHz (131 db BDR)
- Third order intercept:
 - *+26.5 dbm IP3 at 4 KHz (107 db IP3DR)*
 - +10 dbm IP3 at 2 KHz (96 db IP3DR)
- No AGC – 1v pk-pk audio limiter provided

BDR: A Comparison – 5 KHz

Blocking Dynamic Range
(5 KHz spacing - Preamp Off)

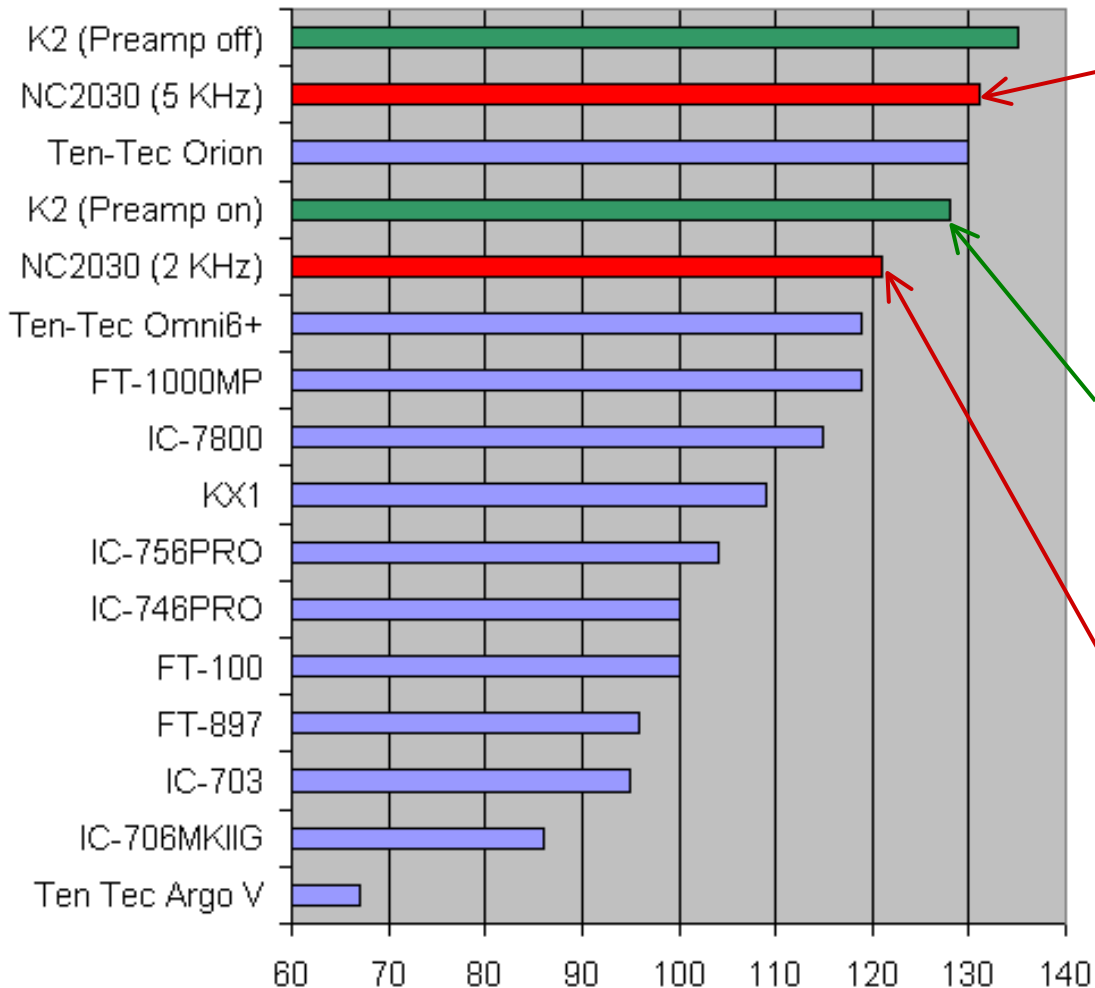

NC2030 *at full sensitivity*, is within *4 db* of the best rigs which were measured with their RF pre-amps *off*.

Note: With the RF pre-amp on, the K2 is actually *3 db worse* than the NC2030

Even at only *2 KHz*, the NC2030 performs better than all but two rigs measured at *5 KHz*.

IP3DR: A comparison – 5 KHz

Third order intercept Dynamic Range
(5 KHz spacing - Preamp Off)

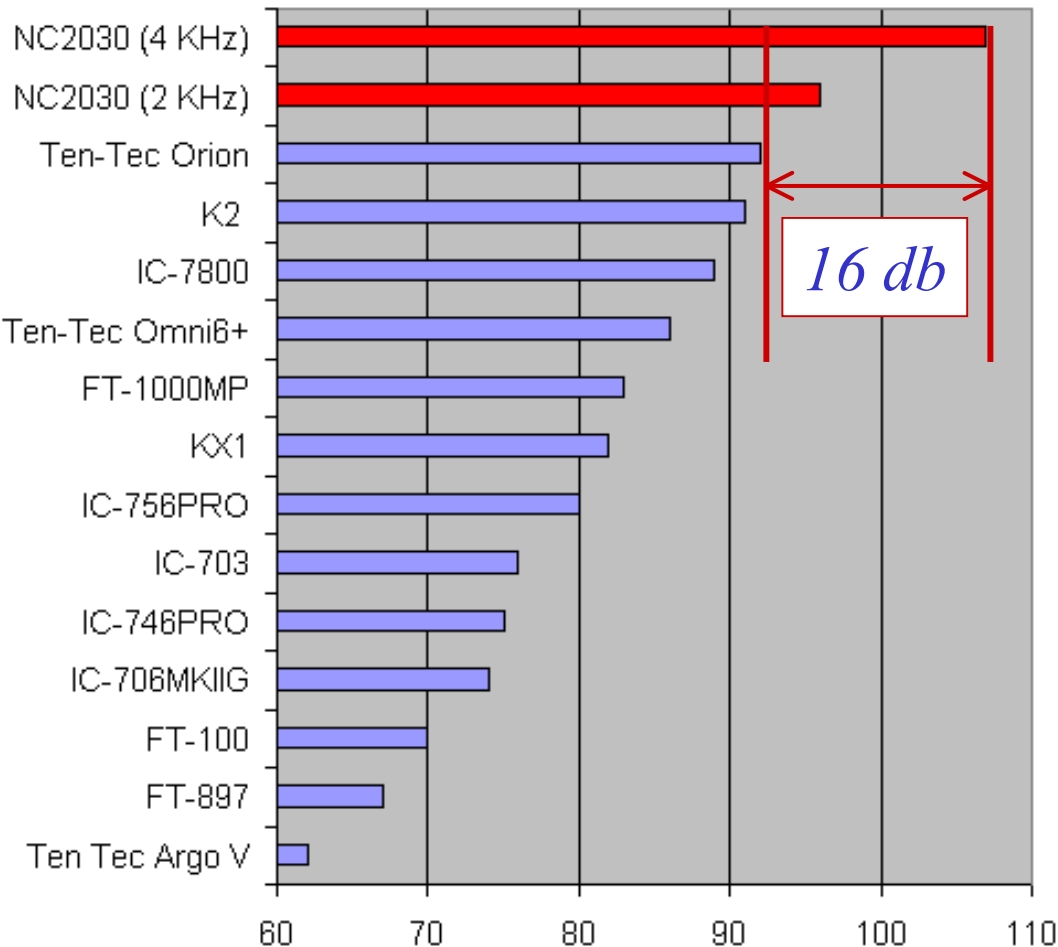

NC2030 at *4 KHz* is 16 db better than the best at *5 KHz*

NC2030 at *2 KHz* is still *4 db* better than the best at *5 KHz*.

Not an apple-to-apples comparison since NC2030 is at *full sensitivity at 4 KHz* spacing while other rigs have *pre-amps off at 5 KHz* spacing

Receiver Power vs. 5 KHz IP3 Dynamic Range Performance

Current Drain vs. IP3 DR

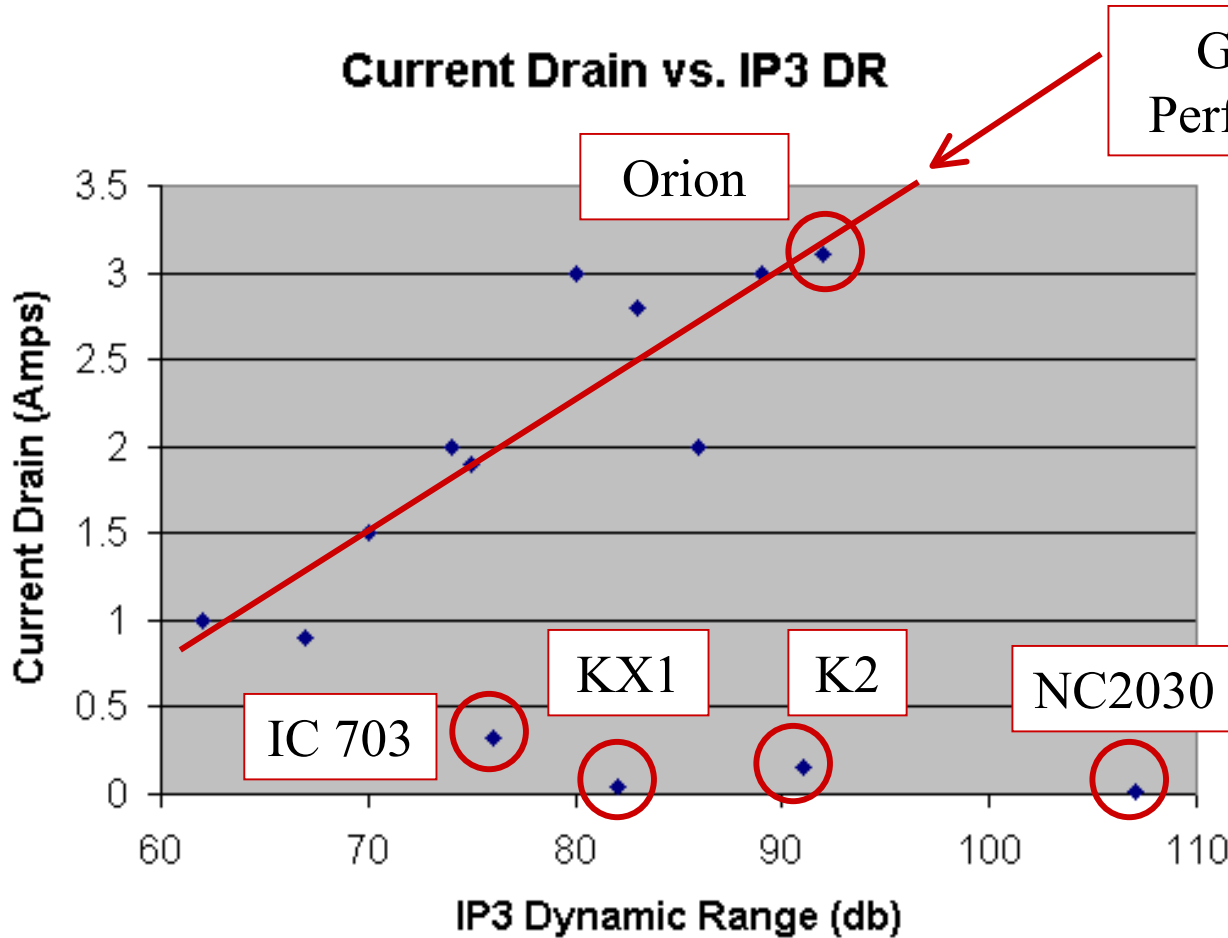

General Power vs.
Performance trend line

The second best rig, the Orion, uses **280x** the power of the NC2030.

A K2 in its lowest power mode still uses **14x** more power than a 20m NC2030

The NC2030 uses the least power, yet gives the best performance

A Look at BDR vs. IP3DR

- Good blocking dynamic range (front end overload) is easier to achieve than good IP3 dynamic range (distortion - spurious on frequency signals).
 - *Ten Tec Omni example:* 5 KHz BDR is **130 db**, but IP3DR is only **92 db**. The receiver will begin creating false spurious signals **38 db** before the receiver blocks.
 - In contests RF preamps are turned off, and attenuators are kicked in. Weak signals are gone, but the receiver works ok.
 - IP3 dynamic range is often more **usable** than blocking dynamic range **because IP3DR happens first**.
- => Receivers distort (IP3) long before they block.**

A Look at BDR vs. IP3DR, cont

- IP3DR and BDR is better with the RF pre-amps off.
- NC2030 5 KHz BDR is *131db*, 4 KHz IP3DR is *107 db*, measured at *full receiver sensitivity*, a *24 db* difference.
- Although the NC2030 5 KHz BDR is 4 db short of the best, the IP3DR *at full sensitivity* is *over 16 db* better giving *superior usable performance* compared to other rigs.
- *16 db+* IP3DR edge at *full sensitivity* allows NC2030 to copy weak signals in the presence of very large signals when others cannot.

⇒ *“You can’t work them if you can’t hear them.”*

Why is this receiver so good?

- The detector has bandpass filtering built in.
 - The post detector pre-amp has low pass filtering.
 - The detector has under 1 db of conversion loss rather than the normal 6 to 8 db. *No RF preamp is needed.*
 - Superhet has RF preamp, first mixer, and post mixer IF amplifier *that see all the signals on the band* (300 KHz wide?), *a very tough large signal environment, requiring lots of power for reasonable performance.*
 - NC2030 detector & preamp roll off signals starting *800 Hz* away. *The front end only sees close in signals.*
- => The NC2030 has a superior front end architecture for both distortion and blocking.***

Receiver Filter Design

- Crystal filters are designed around crystals that have very high Q s.
 - A Q of 100,000 is not uncommon
 - CW crystal filters tend to have a very steep frequency roll off with relatively few crystals.
 - Each crystal contributes a high Q pole to the filter transfer function.
 - *High Q filters tend to ring – sounds “hollow”.*
 - Can be very fatiguing to listen to if the band is noisy.
- => Filter ring is an almost universal characteristic of today's QRP transceivers.***

Receiver Filter Design, cont.

- **NC2030 filtering was designed to minimize ringing.**
 - *Rx has a very natural, open sound, an improved audio experience.*
- More gradual low Q Butterworth filters were used rather than steeper high Q Chebychev or Elliptic filters.
 - *More stages are needed for the same roll off.*
- 750 Hz, 9 pole Butterworth LPF filter was used as the rig's main “brick wall” filtering.
- 5 pole Elliptic SCAF low pass filter was used as a “comfort filter” to sharpen up high frequency roll off.
 - *Signals tend to “pop out” as the receiver is tuned across the band.*
- Variable frequency SCAF filter cutoff is normally set *higher* than the Butterworth main filter so that it does not contribute to ringing, but still helps roll off.
 - SCAF can be used to further narrow RX bandpass.
 - *Can help dig weak ones out of the noise*

Main Receiver RC Filters

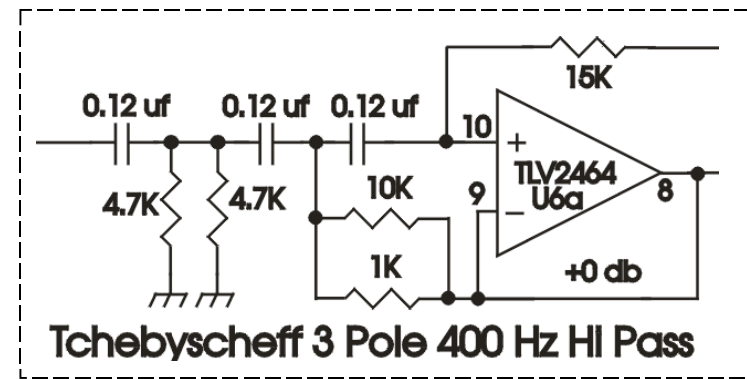
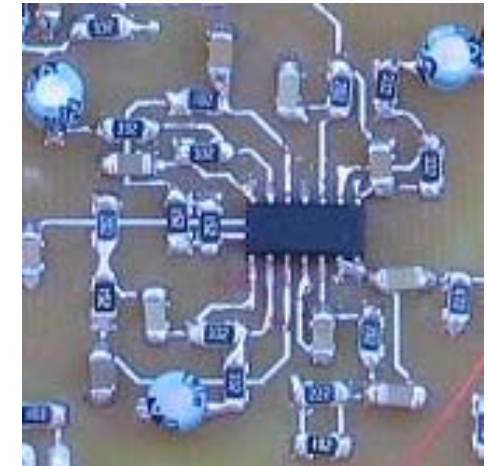
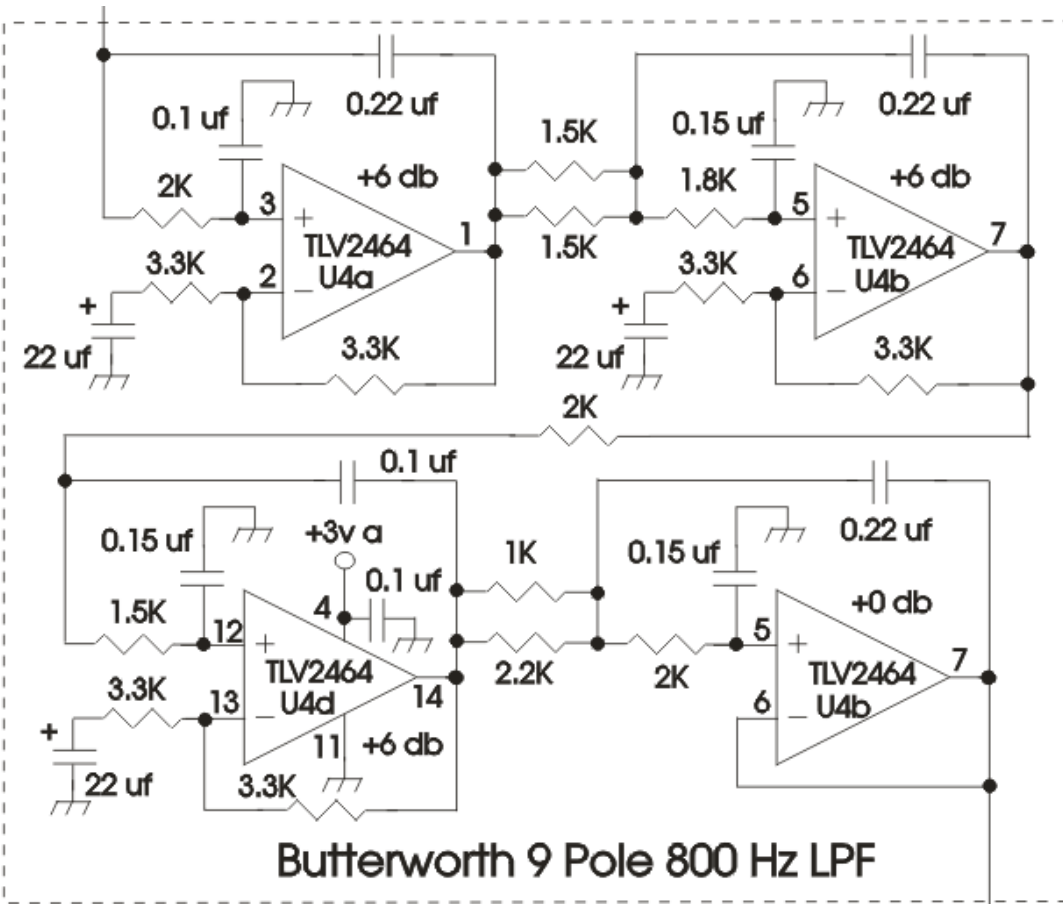

⇒ 400 to 800 Hz main filter passband

⇒ **RC** used in place of **LC** to eliminate *inductive AC hum pickup*

Receiver MP3 Listening Test

- Audio A/B comparison of *NC2030 & K2*
 - *Same on-the-air signal*
- Two MP3 samples: *first* NC2030, *then* K2
- First test is signal with background impulse band noise
- Second test is W1AW code practice with lots of QSB.
 - On second test the tester can be heard varying the NC2030 *SCAF filter* to narrow the passband and bring the signal up.

Beta Test Feedback

"The RX seems to excel at weak ones popping out of the noise."

"I love the RX! It is very quiet and it sounds right!!!!

I have been comparing the rig for a modified Yaesu Mark V and the little rig kicks butt!.....

The other night around mid-night was super to listen on. You don't think the band is open because the rig is so quiet and then bang there is a loud signal!"

Beta Test Feedback

"I have to say that with this particular RX design, I can hear the key clicks, distorted CW waveforms, and bandwidth hogs of the YaeComWood rigs out there!! what a mess. My Jupiter seems to mask off the garbage signals and leave me in blissful ignorance (hihihi).

I could easily distinguish a clean K2 or K1 signal from the rest."

Temp Stability Testing

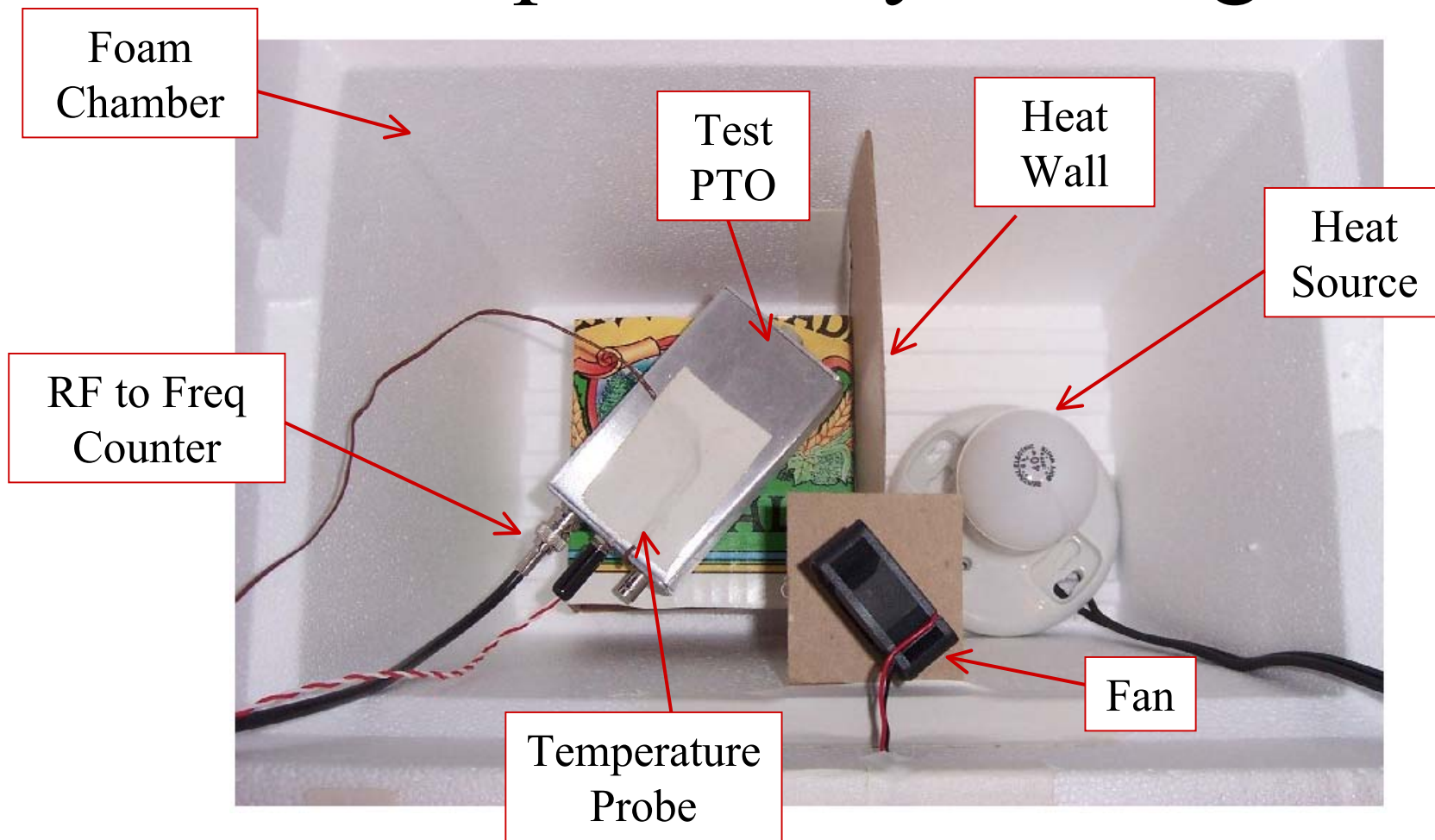

- Test PTO and homebrew temperature chamber

Temp Stability Testing, cont.

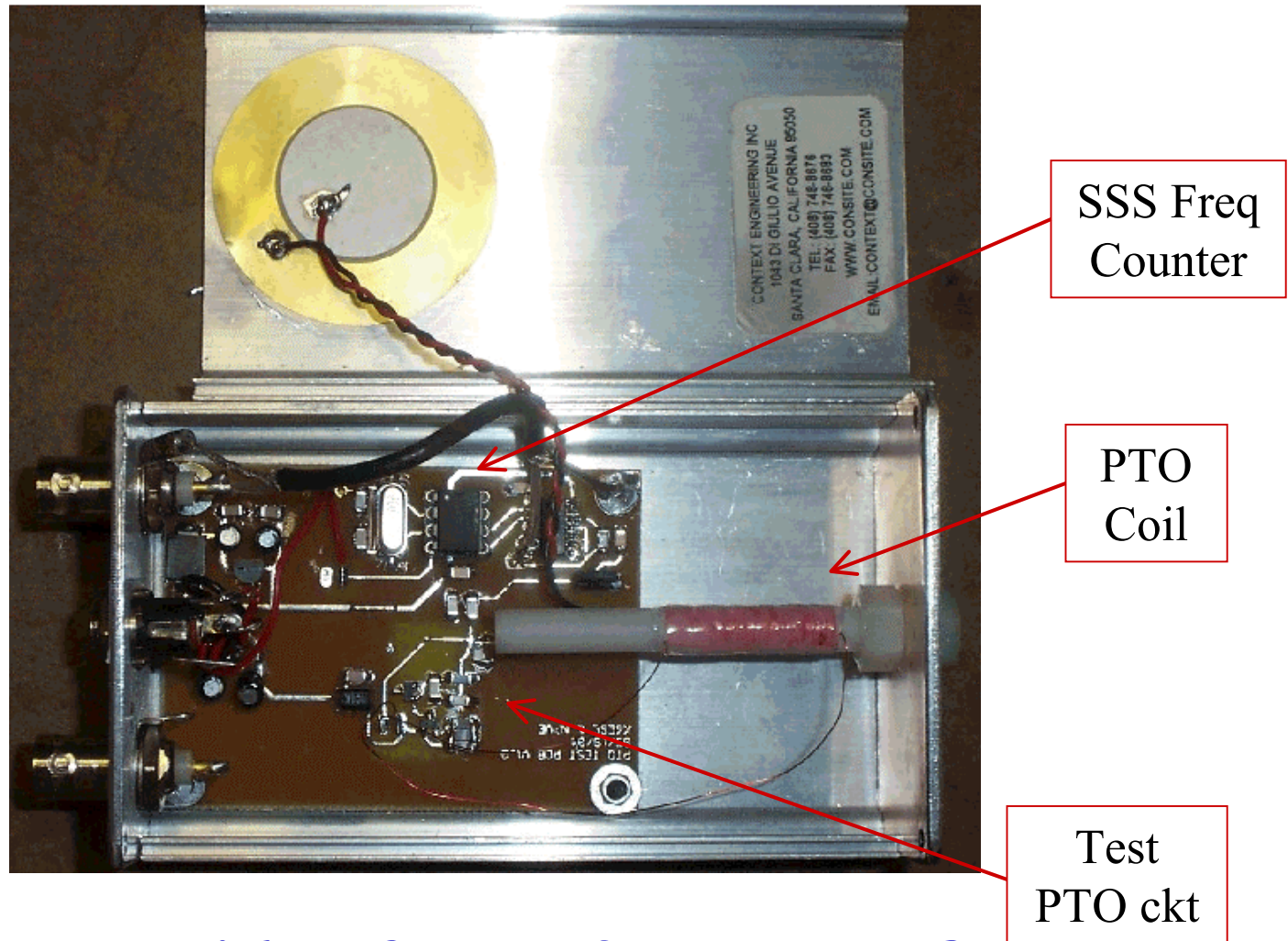

⇒ *Inside of Test 3 MHz PTO*

Temp Stability Testing, cont.



*PTO coil form w/
tuning rod*

⇒ PTO coil being machined

Temp Stability Testing, cont.

Frequency vs. Temperature

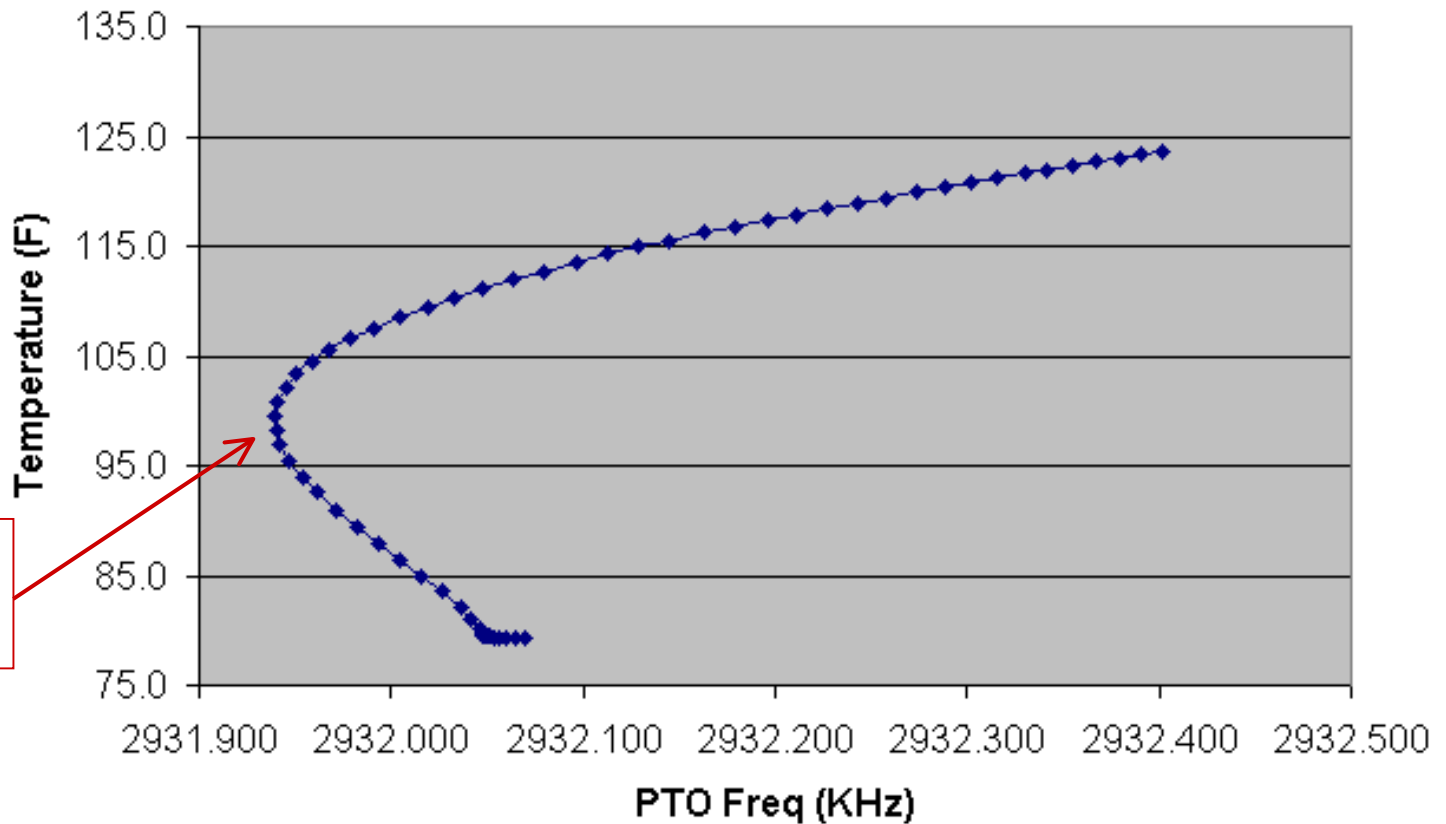

Delrin rod deforms

- Testing found Delrin PTO coil form rod deforms at high temp
- *Difficult to frequency compensate PTO drift*

Temp Stability Testing, cont.

Temperature vs. Frequency

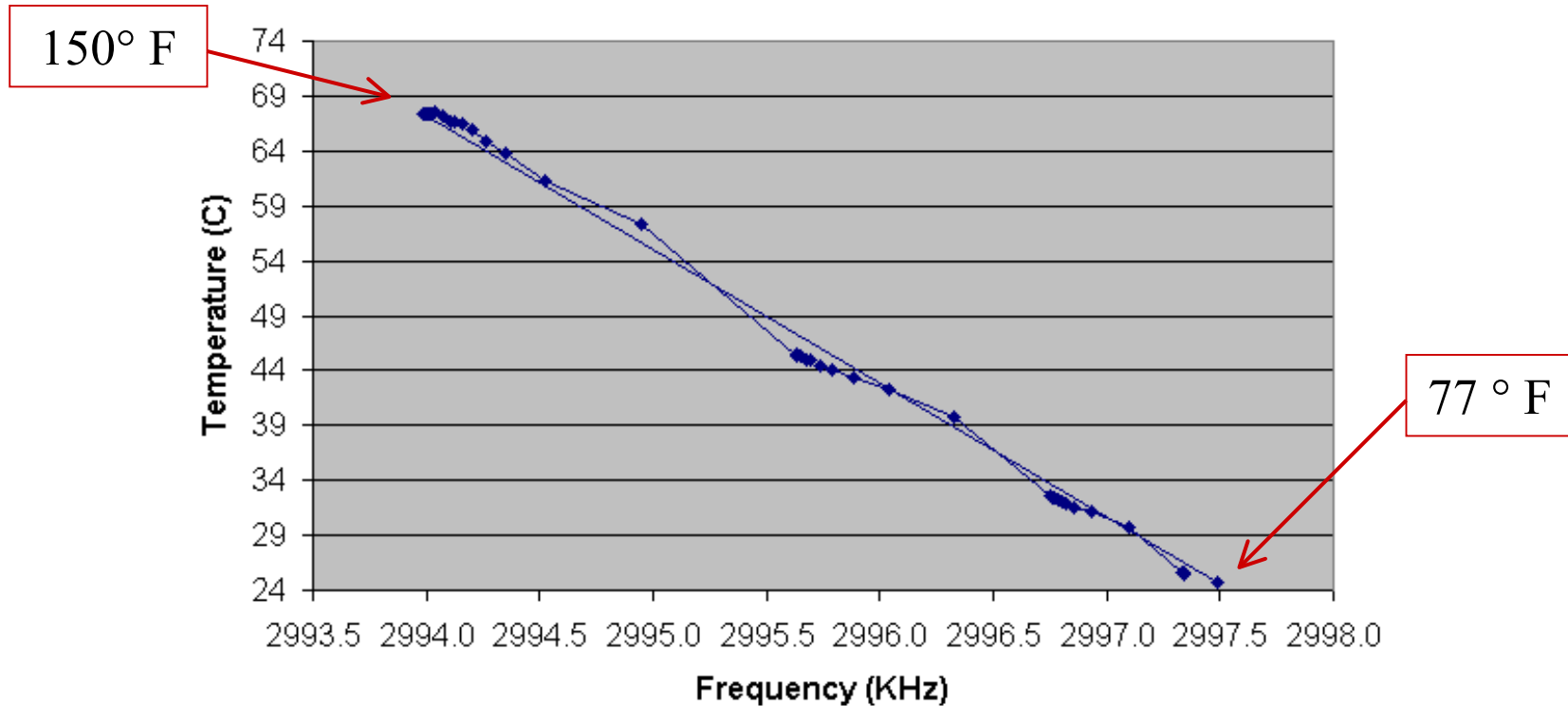

- Nylon Kevlon exhibited linear frequency vs. temp curve
- *Easy to frequency compensate using N220 type caps*
- After compensation, test PTO drifted **73 Hz** over a **63 F** temperature change

Class E Transmitter

- **NC2030 was designed for minimum power, both RX and TX.**
- Advantage of Class E – Low current requirement
 - 5w output with around 550 ma of current drain (13.8v)
 - Typical 5w QRP rig requires ~ 1 amp when transmitting
 - Batteries *last twice as long* or *weigh half as much*.
- Disadvantage of Class E – Fixed power output
 - Rig targeted at 5w at 13.8v, 4w at 12v.
 - Power could be varied at home by using a variable voltage power supply to feed the final.
 - Rig operates from ~7 to 15v input.

Class E Transmitter, cont

- “Fragile” Class E PA has been *SWR protected*.
 - PA protected from over voltage (open antenna)
 - PA protected from over current (shorted antenna)
- Class E output designed for “*no tune*” operation
 - No more tweaking coils for proper power output
- NC2030 finals: Three BSS170s MOSFETs
 - 800 mW version of the 300 mW 2N7000
 - *Five watts from three TO-92 transistors!*
 - At \$0.05 each, SWR protection costs more than the PA
 - => *But who wants to burn out finals in the field?*

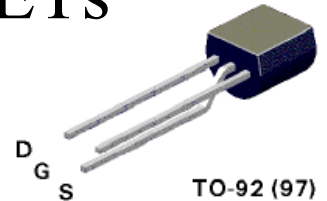

No Tune, SWR Protected, Class E Tx

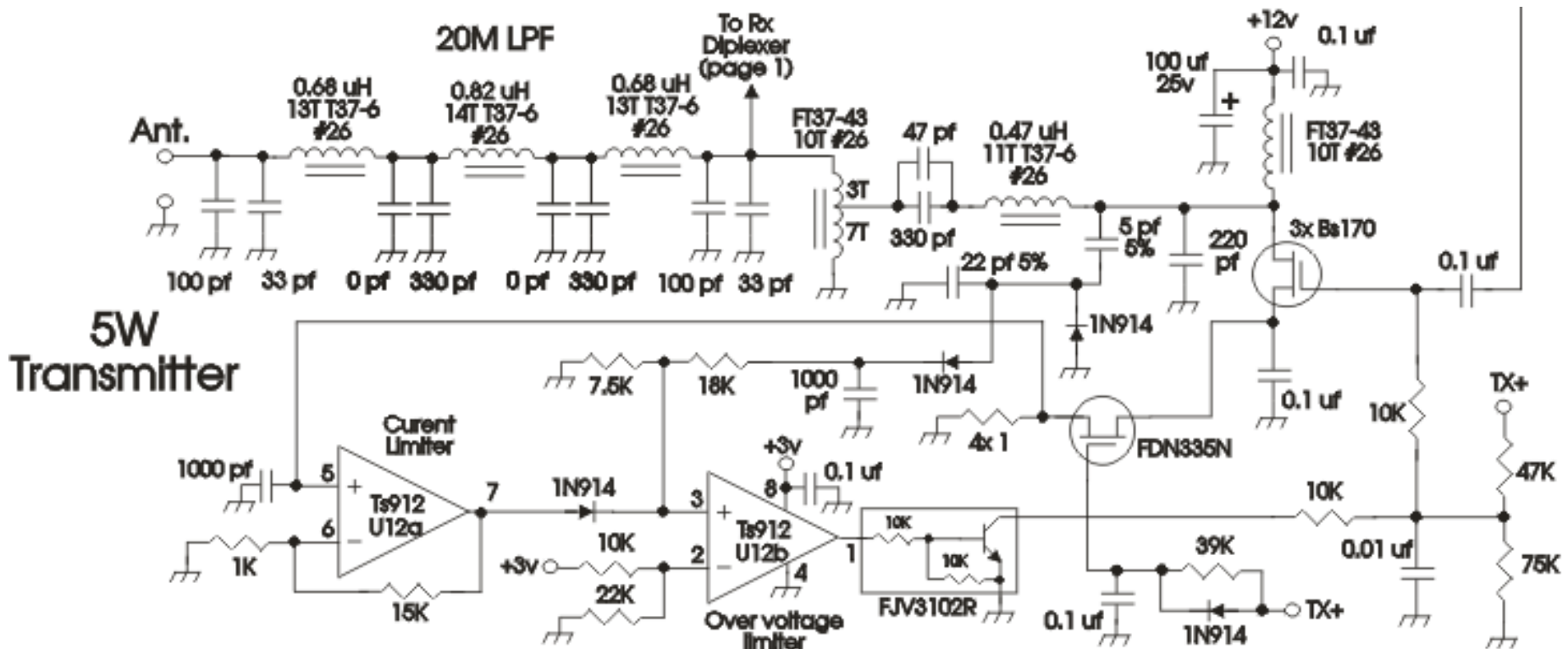

- *High impedance over-voltage protection*
- *Low impedance over-current protection*
- *“No Tune” Class E output*

PA Section of the NC2030

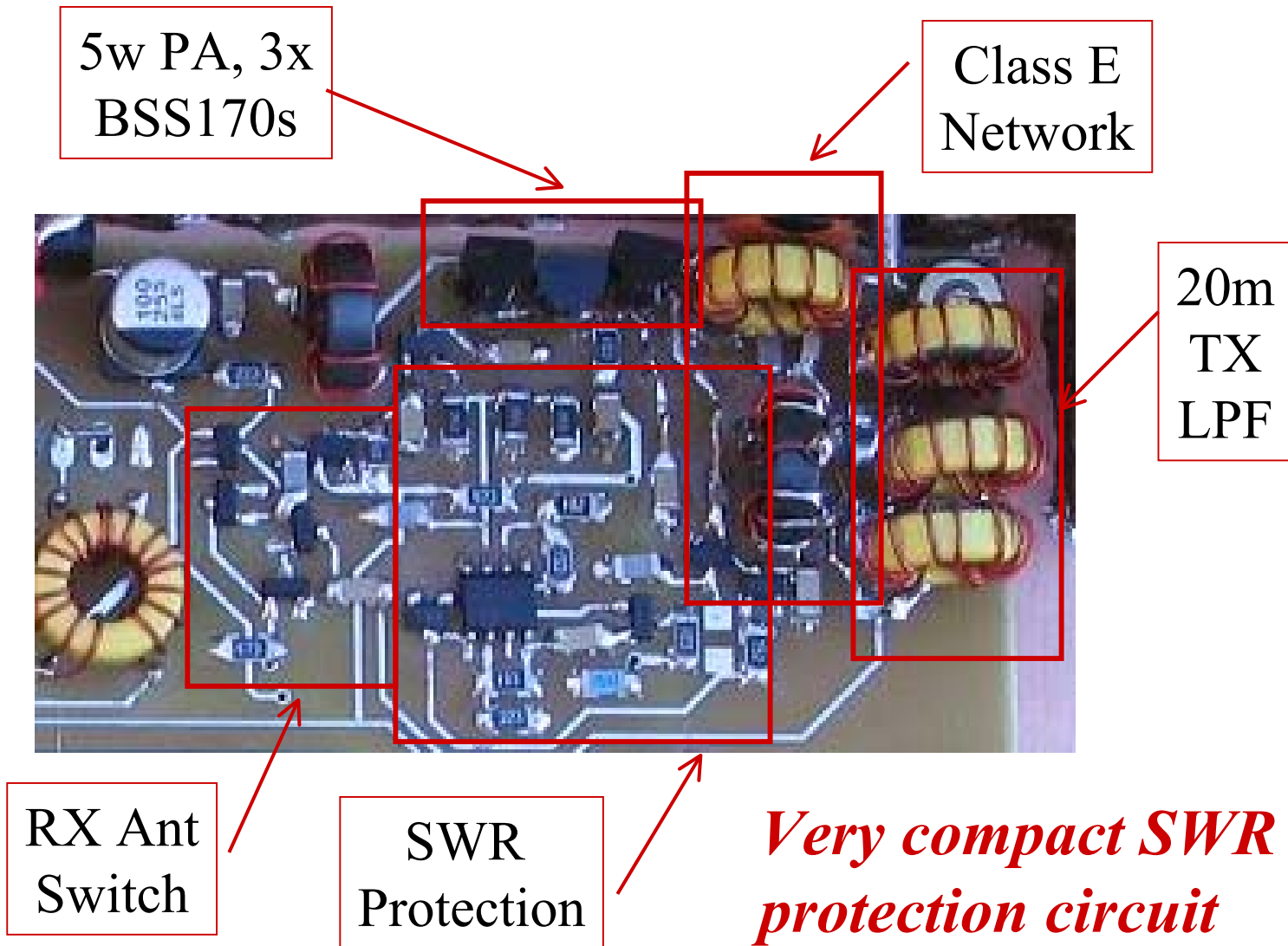

Class E Drain Voltage Waveform

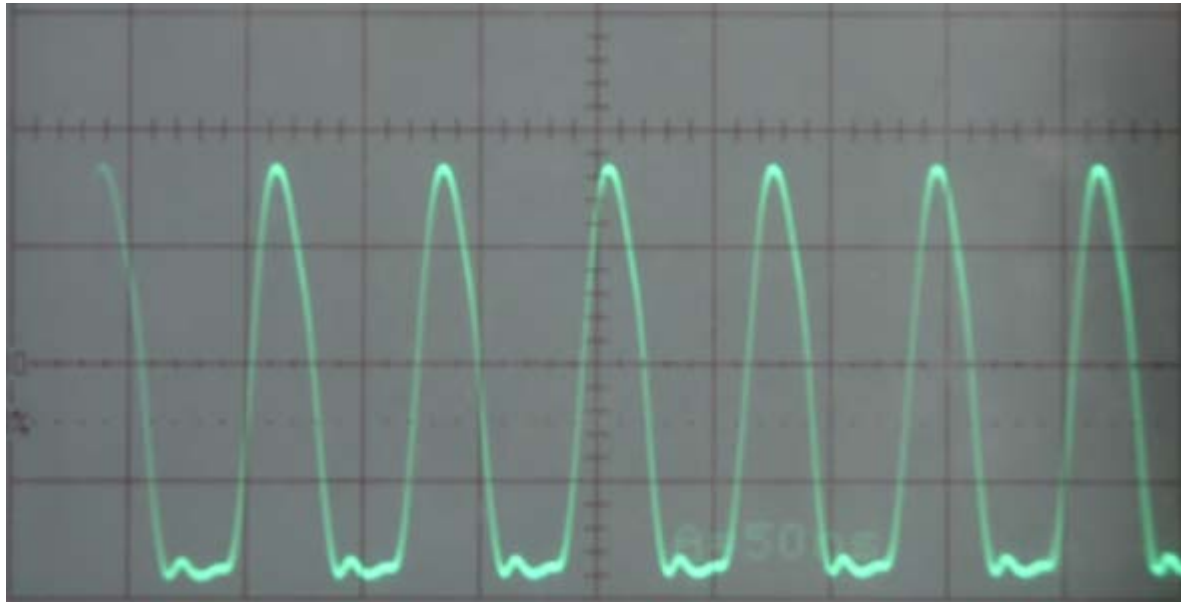

- Scale 10v/division
- ~ 38v at peaks, 5 w output
- MOSFETs saturating at ~ 2v minimum drain voltage
- For comparison, Class C devices run 24v peaks w/ 12v supply

Transmitter Spectrum

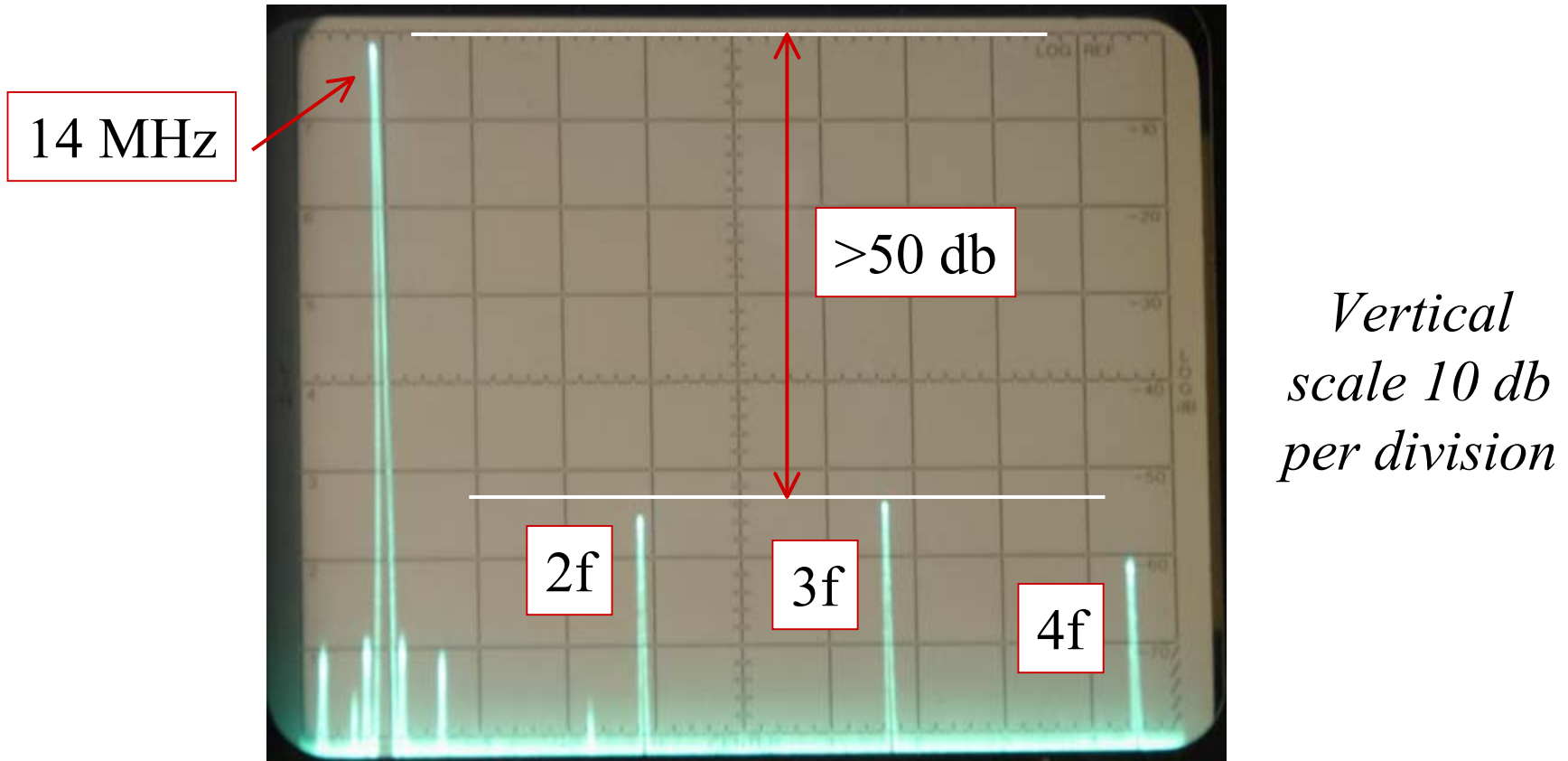

- Harmonics and mixer spurs all over 50 db down
- Easily exceeds harmonic suppression regulations

TX Keying Waveform

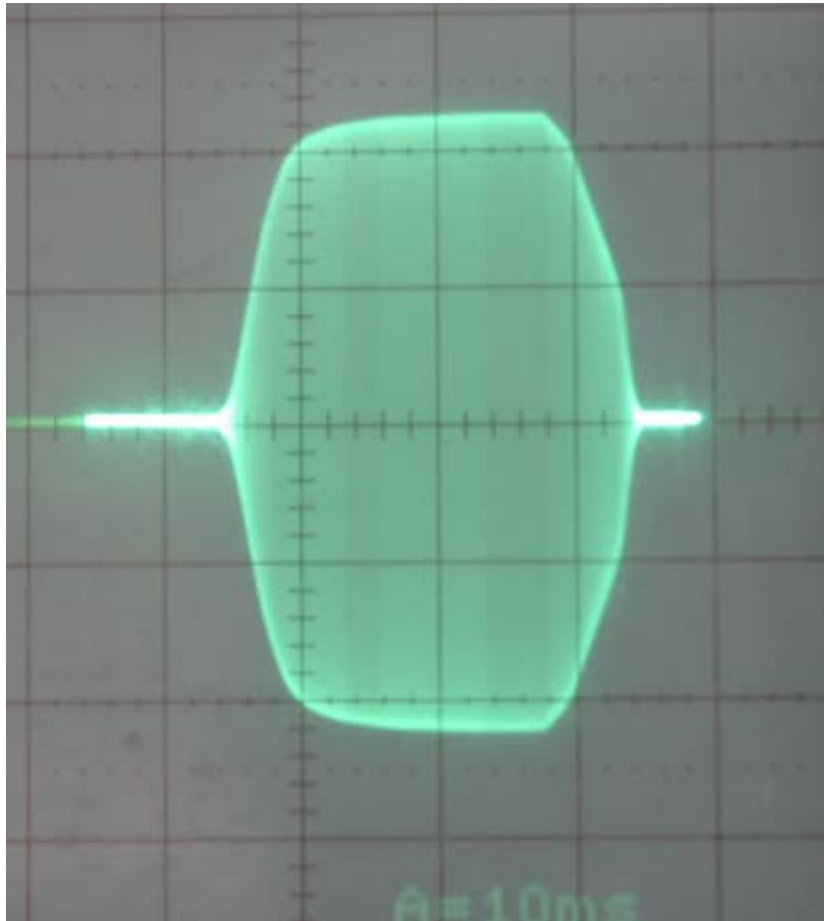

- Very high speed “dot”
- 10v per division vert.
 - Shows 5w output
- 10 msec per division hor.
 - Rise time ~ 5 msec
 - Fall time ~ 6 msec
- Output key click clean

Beta Test Feedback

"Much to-do these days about Key-clicks and this rig is super in that area! Looks super on my monitor scope (30 Mhz dual trace). Using 200-250 hz filters and a S-5 reading on the TS-870 and also on the FT-1000 Mark V *the NC-2030 is one of the cleanest rigs I have played with. -+ 200 Hz.*"

"I got unsolicited "**EXCELLENT KEYING OM**" reports on the signal. The TX waveform shaping (10ms trailing edge?) must sound especially good."

Additional Information on CD

- On the CD is the *old NC30 presentation*
 - How a DC phasing receiver works
 - How the switching supply saves power.
 - Old performance comparisons.
- Note: The new NC2030 has the same performance at *5 KHz* spacing as the old NC30 was at *20 KHz* spacing.
 - *and uses less power to boot!*

Additional Information on CD, cont

- Also on CD is a more detailed *class E presentation*
 - Discusses the PA and SWR protection used in the NC2030
- MP3 *NC2030 vs. K2 audio comparison files* included on the CD.
- Slightly out of date white paper on the *high performance quadrature detector* used in the receiver's front end.

Backup Material

Transceiver Block Diagram

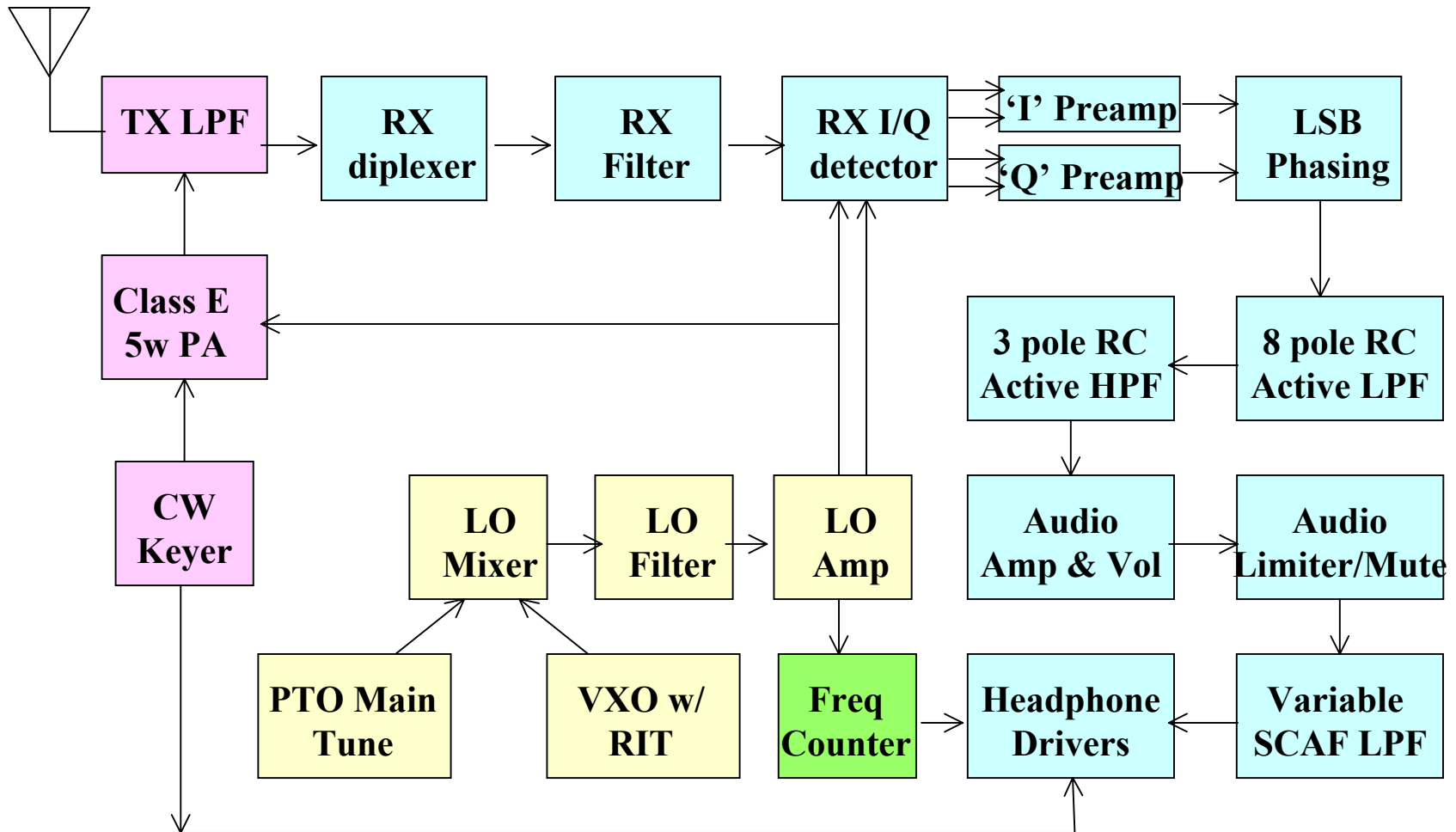

More Beta Test Feedback

"I also had a friend come over to play, his reaction alone was worth seeing. Bottom line he was impressed and said when they kit this he will be first inline! What sold him was how quiet the rig is. He kept turning up the volume to hear some band noise and then heard a few signals when I told him to watch out those are very weak. About that time he tuned to a loud station! After reaching for a bunch of volume control he made a long QSO and couldn't believe how quiet and smooth the RX is! He also couldn't believe how good the break-in was on the little rig."

Beta Test Feedback, cont.

“The DX stations were all pretty weak. The RX seems to excel at weak ones popping out of the noise. It is very much like the RX I enjoyed in my good old K2 (SN #167 circa June 1999). I like the SCAF as well.

I can't judge the sidetone freq very well and sometimes have it set too high for the SCAF bandpass. So I just use RIT and re-center it in the bandpass. Smooth and very useful feature.”

Note: The SCAF cutoff is sharp! Use with caution. :^) Normally the SCAF is set to the highest frequency where it helps with roll off, but does not get in the way.

The “Spot” switch also helps to zero beat another station dead on. No need to “guess” on the RX-TX offset.

Beta Test Feedback

"I got unsolicited "EXCELLENT KEYING OM" reports on the signal. The TX waveform shaping (10ms trailing edge?) must sound especially good.

The QSK was smooth as silk. No thumps or bumps or weird timing of any kind. I can only compare it to my K2 or DSW-II which receive my Highest marks for QSK. Well done Dan/Paul/Engineering team.

The RX is so hot that I frequently had to turn down the AF GAIN (volume) to keep it from distorting the audio! You might want to sell the kit with an optional 20db ATTEN (hihihi). Thank goodness for the LIMITER on the audio!"

*Note: The NC2030 has **no AGC**, but does have an 1v pk-pk audio limiter for your hearing safety. As the rig is tuned, there is often little or no warning of a big signal coming up! If the limiter kicks in, turn the volume down to remove the distortion! There is now an option for a front end attenuator, but that will not change the strong signal-weak signal situation.*